

## TECHNICAL PARAMETERS Vibration exciter S 50350/LS-120

Rated peak force Sine <sub>pk</sub> /Random <sub>RMS</sub> <sup>1</sup> /Shock <sub>pk</sub> <sup>2</sup>	2700/2000/5300 N
Frequency range	2 - 4500 Hz
Main resonance frequency	> 3700 Hz
Max. displacement Peak-Peak <sup>3</sup>	45.0 mm
Max. velocity Sine/Random/Shock	1.5/1.5/2.5 m/s
Max. acceleration Sine/Random/Shock	95/73/160 g
Suspension stiffness	electronically adjusted
Effective moving mass (±5%)	2.9 kg
Max. payload	25 kg
Total mass	280 kg
Magn. stray field without/with degaussing <sup>4</sup>	< 8.5/< 1.4 mT
Armature diameter	120 mm
Interlocks	Field coil temperature, displacement, cooling air, overcurrent

1) Random force according to ISO 5344:2004

2) Theoretical maximum shock value. Depends on payload, amplifier, shock and shock width

3) Impact by moving to static mass and frequency is possible

4) measured at 150 mm above armature

For long-term tests, the load must be reduced to 80 %. Continuous operation at maximum load can cause damage.

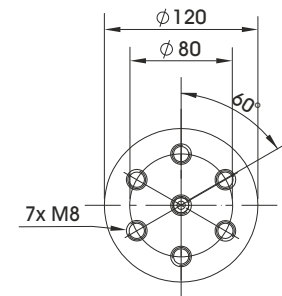
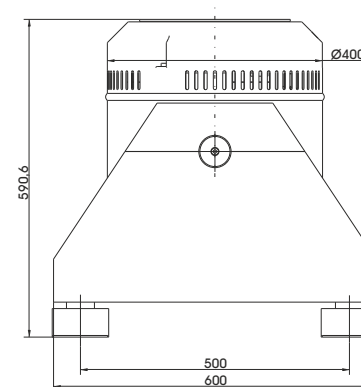
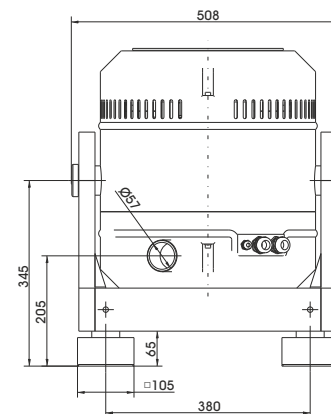

Armature (Standard)

## SCOPE OF DELIVERY, OPTIONS AND FEATURES OF THE SYSTEM

<p><b>Scope of delivery:</b>          Vibration exciter 2.7 kN          Trunnion mount          Power amplifier 15 kVA          Cooling blower          Connection cable (5 m)          Power cable (5 m)          for amplifier (CEE 32 connector)          Blower hose ø60 mm (5 m)</p>	<p><b>Options:</b>          Different thread inserts in the armature at customer request          Degauss kit to reduce stray magnetic field          Squeak&amp;Rattle (Silent operation without blower)          Thermobarrier (-40°C to +140°C)          Chamber leadthrough          Remote control (Software)          ASM-Mode (Auto Shutdown Manager)          Silencer          for cooling blower (Noise reduction up to 6 dB(A))          Acoustic enclosure          for cooling blower (Noise reduction 15 - 23 dB(A))          Cable extension          Factory acceptance test</p>	<p><b>Options:</b>  <b>TIRA EMS</b> Energy Management System          Operation with temperature-controlled cooling blower (and optional with variable field strength)</p> <p><b>Features:</b>          Vibration isolation &lt; 6 Hz          Coarse filter unit          Fully automatic electronic load compensation          Electronic zero point regulation with adjustable stiffness          Automatic centering of the armature          Made in Germany          Servicehotline</p>
---	--	---

## TECHNICAL PARAMETERS Amplifier A 1 02 11 021 T SV

Max. output power <sub>RMS</sub> (factory-set)	15000 VA
Frequency range	DC - 5 kHz
Voltage <sub>RMS</sub> , max.	212 V
Current <sub>RMS</sub> , max. (factory-set)	40-100 A
Signal input voltage <sub>PK</sub>	±10 V
Total Harmonic Distortion (at 70A <sub>RMS</sub> , 200 Hz)	< 0.2 %
Signal to noise ratio	> 80 dB
Field voltage (factory-set)	140-280 V
Field current (factory-set)	6-8 A
Total mass	330 kg
Dimensions (WxHxD)	600 x 1740 x 800 mm
Power supply (Standard)	3~ / N / PE 400 V±5% 50 Hz, CEE 32
Recommended fuse protection	32 A slow
Max. power consumption at 400 V (incl. blower)	17 kVA
Interlocks:	Overload, Temperature, Displacement, Cooling air, Phase monitoring, Emergency stop
<b>Features:</b>	
Field supply integrated	Mains switch and integrated line filter
Field voltage/Field current variable according to customer spec.	Color Touch Screen
4 Sigma peak current	
Electronic zero-point-regulation (TMC)	

## TECHNICAL PARAMETERS Cooling blower TB 0310

Volume flow rate	max. 315 m³/h
Total pressure difference	max. 290 mbar
Power	4 kW
Frequency	50 Hz
Hose diameter	60 mm
Hose length (Std.)	5 m
Total mass	42 kg
Dimensions (WxHxD)	382 x 384 x 432 mm
Sound pressure level, max.	max. 69 dB(A)
Power supply (standard)	by amplifier rack
Max. current consumption at 400 V	7.2 A
<b>Options:</b>	
Silencer TB 0310-SI (Noise reduction up to 6 dB(A))	Dimensions (LxD): 308 x 82 mm Mass: 0.58 kg
Acoustic enclosure TB 0310-AE (Noise reduction 15 - 23 dB(A))	Dimensions (WxHxD): 860 x 760 x 650 mm Mass: 55 kg
Hose length according to customers request (up to 10 m)	



Cooling blower TB 0310



Silencer TB 0310-SI (optional)



Acoustic enclosure TB 0310-AE (optional)